



**LIVE CHAT**  
Click Here  
Leave a Message  
Live Chat by LivePerson

 Search

- HOME
- PRODUCTS
- CUSTOM/OEM
- TECH SUPPORT
- TECH LIBRARY
- APPLICATIONS
- FREE CATALOG

**Technical Questions?**  
To contact us  
[CLICK HERE](#)

Home > [Tech Notes](#) > Troubleshooting an RS-232 to RS-485 Interface Converter

## Troubleshooting an RS-232 to RS-485 Interface Converter

[.pdf Format](#)

- [RS-485 Quick Guide](#) - Just the Essentials on a Single Piece of Paper
- [RS-485 Problem Solver](#) - Trouble Shooting Guide Walks You Step by Step

Have you ever been stuck in the field trying to troubleshoot a faulty system? When communications are suspect you'll want to be armed with information on how to field-test an RS-232 to RS-485 converter. This article gives detailed instructions on how to do that in a two-wire system.

When you're using a RS-485 converter that can be set up for 2-wire or 4-wire RS-485 operation, the RS-485 Receiver can be enabled (Echo On or RS-422 RX Enable) as in 4-wire mode, and the TD(A) & RD(A) connected, and the TD(B) & RD(B) connected as in 2-wire mode, to "loop" the output back to the inputs. Refer to the Table for a list of models with a easily moved Echo/RX Enable Switch or Jumper. With some converter models Echo can be changed by soldering, but to keep things simple, this procedure does not cover that option.

When you have a converter without a Echo On option, you need a second RS-485 port or converter to receive the signal transmitted by the first OR to transmit a signal to be received by the first. This is because a 2-wire RS-485 port is half duplex. It either transmits or receives, but not both at the same time. While transmitting, receive is disabled, while receiving, transmit is disabled and tri-stated. The Data A(-) line from one converter is connected to Data A(-) on the other, and the Data B(+) from the first is connected to Data B(+) on the second.

A terminal program is opened to access one port for transmit, another port for receive, and data is transmitted from the first port to the second. Next data is transmitted from the second to the first.

If data is received and transmitted in both directions, the port/converters are most likely fine. ComTest (a B&B program) can open two sessions, one to access each Com port being used.

Serial Card Models With RS-485 (All Have Rx Jumper) Set RX Jumper to 422 mode		RS-485 Models With Receive/Echo Jumpers or Switch	RS-485 Models No Echo Jumper
ISA BUS		485BAT3 - sw1B Off 485CON - install no jumper pins #18 & 21 485COR - install no jumper pins #18 & 21 485CSP2 - Echo on 485DRC - sw2 Off 485DRJ - sw4 Off 485HSPR - JP2 Off 485LDRC - sw2 Off 485OI9TB - JP1B On 485OIC - JP1 Off 485OICR - JP1 Off 485OISPR - JP2 Off 422OPINB - JP4 422 485OT9L - sw5 Off 485OTLED - sw5 Off 485TBLED - Echo On	485CARLP9A 485COSN* 485COSR* 485LP9N 485LP9R 485LP9TB 485LPCOR* 485SD9TB 485LP9TBN 485LPRJ 485PTBR* 485SD9R 485SD9RJ  * solder echo
3PXCC1A	JP1C - port A		
3PXCC2A	JP1C - port A JP2C - port B		
3PXCC4A	JP8 RX - port A JP10 RX - port B JP14 RX - port C JP12 RX - port D		
3PXOCC1A	JP3 RX		
3PXOCC2A	JP1B RX - port A JP2B RX - port B		
3PXSD4A	JP3 RX - port A JP4 RX - port B JP7 RX - port C JP8 RX - port D		
PCI BUS			
3PCIOSD1A	JP4 RX		

3PCIOSD2A	JP4 RX - port A JP6 RX - port B
3PCISD1A	JP1B (RX)
3PCISD2A	JP1B(RX) - port A JP4B(RX) - port B
3PCISD4A	JP3B RX - port A JP4B RX - port B JP6B RX - port C JP7B RX - port D

Windows 95/98/SE/ME/2000 or NT 4.0: Use ComTest from our Website to check serial ports assigned Com1 or higher under Windows. It can access Com ports 1-8, including USB serial devices. ComTest will let open two different ports to check data from one to another or set DTR high to power a port powered device and raise RTS to transmit and lower it to receive with RTS controlled Converters or ports. [ComTest Features](#).

MS-DOS: Use Simpterm from our Website to check motherboard or ISA based serial ports under DOS. Do not use SimpTerm with Windows. The procedure is similar, but operating details are different.

#### Download & Install The Program

1. Before starting, make a Directory Folder (such as Test) on your hard drive to use when downloading the program.
2. Go to the B&B Electronics Mfg. Co. Website. <http://www.bb-elec.com>
3. Select Support
4. View the right sidebar for Most Popular Downloads, Software
5. Select ComTest
6. Download into the directory (test) you previously made.
7. Quit your web browser.
8. Open the directory (test) you downloaded to.
9. Double-click com\_test.exe
10. After file extraction is done, close the DOS window.
11. Double-click Setup within the Test folder.
12. Click Next, then Click Next.
13. Select destination directory. (default is C:\Program Files\B&B Electronics)
14. Click Next.
15. Click Finish button after "Installation Complete" message.

Note: If operating under Windows, a Com port number must be assigned by Windows, and it must not be used by a serial mouse or open by another application.

#### MAKE DATA CONNECTIONS:

Refer to the figures for Serial Card connectors, RS-485 Converters with Echo or RS-485 Converters without Echo. Set the Echo On or Receiver to RS-422 mode (4-wire 485 mode).

When the connectors use DB9, DB25 or RJ11 connectors, It is usually easiest to wire a matching connector or cable according to the pinouts. Refer to figures.

Some models can be looped back with switches as below:

- 485DRJ - sw1 - set on, sw2 - set on, sw4 - set off
- 485DRC or 485LDRC -sw3 - set on, sw4 - set on, sw2 - off (on is up and away from PCB)
- 485OT9L or 485OTLED - sw6 - on (2W), sw7 - on (2W), sw5 - off (on is toward outside/case)

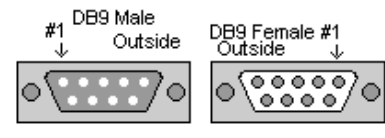

Note: DB9 & DB25 pin numbers are molded into the connector. To locate pin #1 on the male connector hold the connector horizontally with the row with the most pins on top, the upper leftmost pin is #1. On a female connector, the upper rightmost is #1.

### Serial Card Loopback Connections

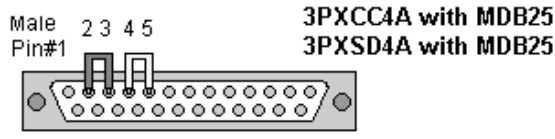
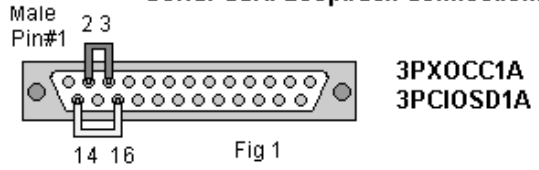

MDB25 is a optional cable from RJ45M to DB25M

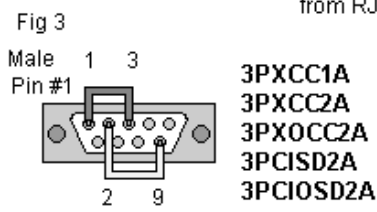

MDB9 is a optional cable from RJ45M to DB9M

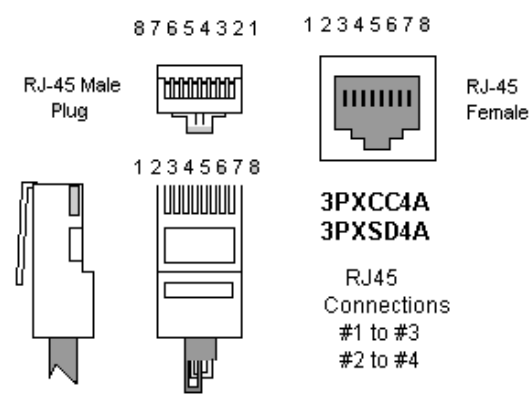

CONNECTIONS - Models With Echo Jumper

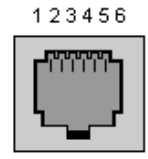
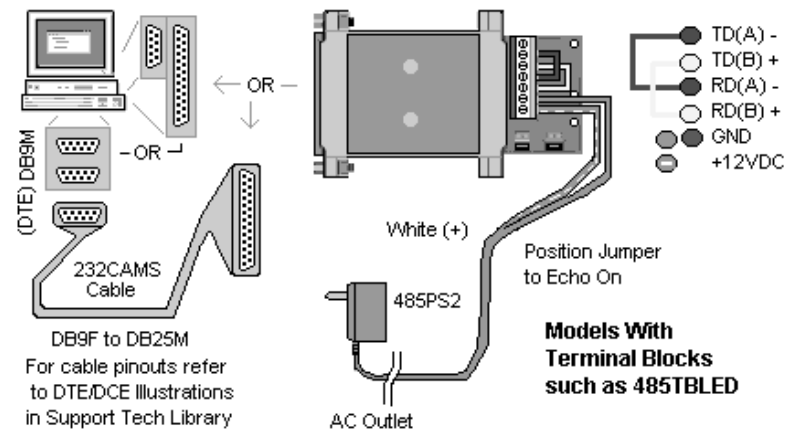

Female Jack

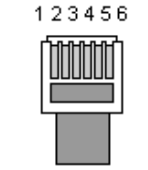

**485DRC**  
**485LDRC**  
**485OT9L**  
**485OTLED**  
 Set Switches to 2-wire mode and Echo or RX to 422 mode

**485DRJ**  
 Set SW1 ON  
 Set SW2 ON  
 Connects #1 to #6  
 Connects #2 to #5  
 Set SW4 OFF to Enable Echo

Do Not Install Echo Off Jumper between pins #18 and #21 during test

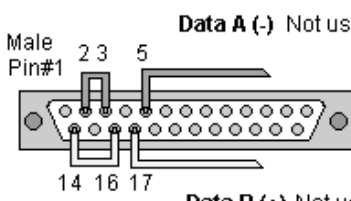

**485HSPR**  
**485OISPR**

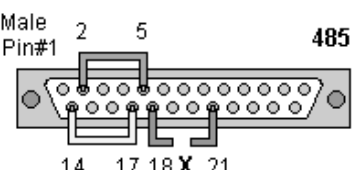

**485COR**

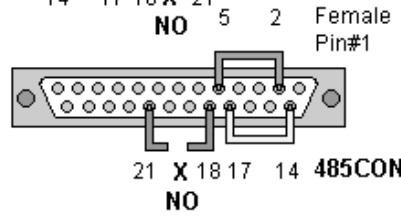

**485CON**

CONNECTIONS - Models Without Echo Jumper

### 2-Wire RS-485 Connections - 2 Converters Required To Check

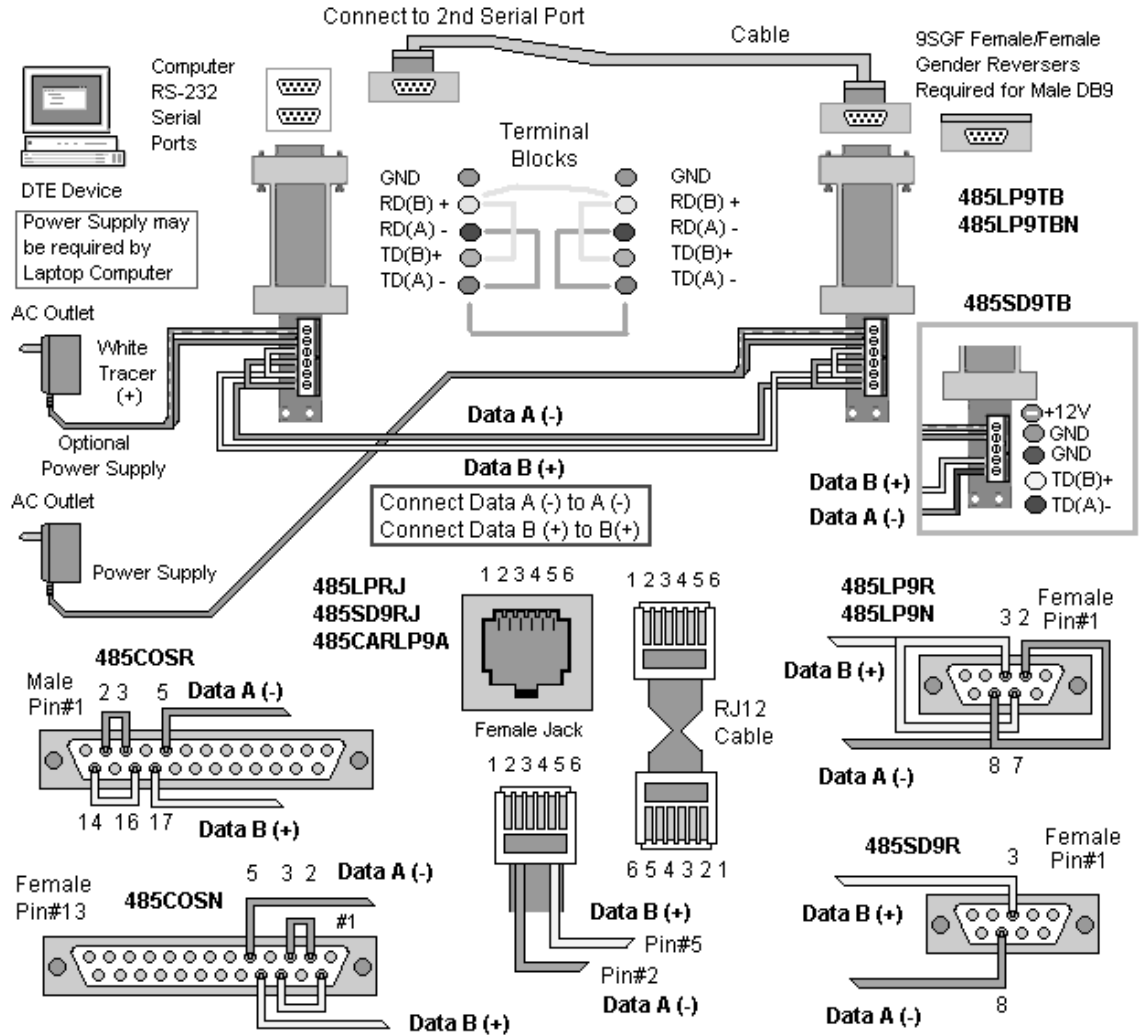

#### USING COMTEST TO CHECK SIGNALS - models with echo jumper

1. Make the Test Connections for Loopback and the required setting to Enable RX or Echo.
2. Start ComTest from your Programs menu under B&B Electronics.
3. Select the Com port number you want to check. ComTest will only show Windows based Com ports that are not in use. If another program is using the port, it will not be available. Please close down any other programs that may be accessing the port. If another program is using the same IRQ number that port is using, you will not be able to use both ports at once unless both devices are PCI or USB based.
4. Accept the default baud rate, data bits, parity, stop bits.
5. If you are checking a RTS Controlled Converter or port: Select Options, then RTS (check marked) to set the RTS indicator red. If using a Port Powered Converter requiring DTR Hi for power, make sure the DTR indicator is red, DTR (check marked).
6. Type some characters in the upper window. The same characters should appear in the lower window. Note that the enter key value will be shown in brackets as <0D>

If data is shown in the lower window when typed in the upper, the Converter or port is working.

Actual signal levels can be checked with a oscilloscope. With no termination, the levels must exceed 200 mV at the

receiver, 4 to 4.5 Volts difference between the Data A and Data B lines is typical when the Data lines are active. With a dual trace scope in DC coupling mode, with one channel on Data A, and the other channel on Data B, the two lines can be seen as opposite levels, when A is high, B is low and vice versa. When the transmitter is inactive and properly powered, 4 volts of bias voltage between Data B(+) to Data A(-) is typical for B&B RS-485 models without device connections or termination.

#### **USING COMTEST TO CHECK OPERATION WITH 2 CONVERTERS - models without echo jumper**

1. Make the necessary Data A and Data B connections between the two converters, wiring Data A (-) to Data A(-) and Data B(+) to Data B(+).

If the converter requires a bridge jumper between the TD(A) and RD(A), and another bridge jumper between TD(B) and RD(B), connect the bridge jumpers. Refer to figures for Connections - Models Without Echo Jumpers.

2. Start ComTest from your Programs menu under B&B Electronics.
3. Select the Com port number for the first converter.

ComTest will only show Windows based Com ports that are not in use. If another program is using the port, it will not be available. Please close down any other programs that may be accessing the port. If another program is using the same IRQ number that port is using, you will not be able to use both ports at once unless both devices are PCI or USB based.

4. Accept the default baud rate, data bits, parity, stop bits.
5. Start another copy of ComTest and select the Com port number for the second converter.

You will need to be able to open and view both data Windows at once, if only one Window is shown, you will need to change your Windows View settings.

6. Accept the default baud rate, data bits, parity, stop bits (or make sure the settings match the first converter port settings. Note: 9600 baud is the default SD (Send Data) control setting for most B&B Converters.
7. If you are checking a RTS Controlled Converter or port on the first port: Select Options, then RTS (not check marked) to set the RTS indicator dark. (This will be the port to Receive).
8. If you are checking a RTS Controlled Converter or port on the second port: Select Options, then RTS (check marked) to set the RTS indicator red. (This will be the port to Transmit from).
9. If using a Port Powered Converter requiring DTR High for power, make sure the DTR indicator is red, DTR (check marked) for the either port using this type of converter.
10. Type some characters in the upper window for one converter. If the converter is RTS Controlled, the Converter port with RTS high will send to the Converter with RTS low.
11. If data is shown in the lower window for one port when typed in the upper window of the other, the Converter or port is working for Receive. The other is working for Transmit.

The characters typed should appear in the opposite window. Note that the enter key value will be shown in brackets as <0D> and other non-printable control characters will be shown with different values. If the characters appear odd, check that the Data A and B line pair from one converter to the other is not interchanged. Connecting A to B and B to A will invert the data patterns causing the computer Com port to trigger incorrectly on the data. Low or marginal port power can also cause data errors. A external supply may be needed if using a laptop or other low power device. Do not attempt to connect a power supply to a Port Powered device unless the converter has +12 Volt terminals. If you connect a 12 Volt DC power supply to the DTR or RTS line without a current limiting series resistor of 180 ohms to 240 ohms, you will cause damage to the converter circuitry.

12. Next make the opposite port active for transmit. If the converter is RTS Controlled, set RTS for the Transmitting port high, and the RTS low for the receiving port.

13. Type characters in the window for the transmitting port, observe them in the lower window of the receiving port.
14. If each port can transmit from one to the other and receive from the other, the converter is most likely working fine. Any other problem may be software related.

Actual signal levels can be checked with an oscilloscope. With no termination, the levels must exceed 200 mV at the receiver, 4 to 4.5 Volts difference between the Data A and Data B lines is typical when the Data lines are active. With a dual trace scope in DC coupling mode, with one channel on Data A, and the other channel on Data B, the two lines can be seen as opposite levels, when A is high, B is low and vice versa. When the transmitter is inactive and properly powered, 4 volts of bias voltage between Data B(+) to Data A(-) is typical for B&B RS-485 models without device connections or termination.

Note:

1. RTS Control units require RTS hardware control software to operate properly. RTS control timing can be critical for half duplex RS-485 control, and can be erratic under windows.
2. SD Control units require a matching baud rate setting if preset for 9600 baud. Resistors and/or capacitor values may need to be changed.
3. Many Common problems are caused by wiring custom cables for the RS-232 side, especially DB9 to DB25 and not understanding DTE/DCE devices. Usually Rx and Tx are wrong. Refer to our web site Support, Technical Library for DTE/DCE Illustrations.

#### **B&B Electronics ComTest - A Serial Test Program For Port & Converter Testing With Windows**

- A Test Program for Simple Checks of Serial Ports, Serial Converters, Serial DAQ Devices. Works with USB Serial Converters & ISA or PCI Serial Cards
- Serial Port Access under Windows 95/98 and NT 4.0 - Com1-Com8 or above.
- Dual Windows show typed transmit characters in separate window from received characters.
- Transmit & Receive Activity Indicators
- Unprintable Characters Shown in Hex - 2 Digits Within Left & Right Angle Brackets.
- Visual Indication of Handshaking Lines - DTR DSR DCD and RTS CTS. (Red = Hi)
- Option for Setting DTR or RTS lines high or low for port powered devices or RTS Control.
- Option for Repeat Mode - last character or Function Character Sequence is repeated until set off.
- Option for Defining Strings to Output Using F1-F12 Keypress - Useful for DAQ Checkout
- Option for Sending Unprintable Characters - Alt + 3 digit keycode, then release Alt.
- Configuration Settings:
  - Baud Rates 150, 300, 600, 1200, 2400, 9600, 19.2, 28.4, 57.6, 115.2K (9600 default)
  - Parity: None, Odd, Even, Mark, Space (None is default)
  - Data Bits: 5, 6, 7, 8 (8 default)
  - Stop Bits: 1, 1.5, 2 (1 default)

#### **Start ComTest**

1. Connect the device to check to the serial port, or if performing a loopback test, make connections.
2. Select Start, Programs, B&B Electronics, ComTest, ComTest.

3. (If you get Win Port window showing shared modems, click Cancel)
4. ComTest Starts with a Select Port Window.
5. Select the Com port to access or test. (The drop down box shows available ports not in use).
6. Click Ok. Configure Port is shown.
7. Select the needed baud rate, parity, data bits, stop bits. (Defaults are common settings).
8. Type characters - they will appear in the upper window.
9. If performing a loopback test, observe the received characters in the lower window.
10. If sending commands to a serial DAQ device or Smart Switch, enter the control strings and observe the device response or characters returned in the lower window.

#### **To Send Non-printable Characters Using Com Test**

You can send non-printable control characters in a control string by pressing the Alt key and while holding it down, enter the 3 digit character code using the separate numerical keypad on the computer. For example, Esc=27. Press and hold Alt, then press 0 2 7 then release Alt.

For example: The Command for the 232SDA12 digital output is !0SO and bits. Hold Alt and enter 0 0 1 or 0 0 2 or 0 0 4 to set each bit high. Enter 0 1 6 or 0 6 4 to set the 3 bits low. ComTest cannot send the character value of zero.

#### **Defining Strings To Send Using F1 to F12 Keys**

1. Select Options, Strings, then under Key, select the F1 to F12 radio button.
2. Highlight and Delete the default String.
3. Enter the characters to be sent.
4. Select another key to define or OK to close the Window.

Press the F1-F12 key to send the characters.  
Observe the response.

#### **Setting RTS or DTR High or Low**

Select Options on the menu bar.

Select RTS and/or DTR to set Hi. Select to unchecked mode to set Lo.

#### **Exit**

When testing is completed, close the program.

#### **Removing Com Test**

Close the program.

Select Settings, Control Panel, Add/Remove Programs, Select ComTest.

ComTest will be removed from the Program items.

For more information on serial ports, we recommend [Serial Port Complete](#) and [C Programmer's Guide to Serial Communication](#).

---

[Home](#) | [Products](#) | [Partners](#) | [Tech Support](#) | [Tech Library](#) | [Press Room](#) | [About](#) | [Contact](#) | [Site Map](#) | [Privacy Policy](#)  
[Questions or Comments?](#) Copyright © 2012 B&B Electronics Mfg



**ISO 9001:2008**  
CERTIFIED