

# **Toshiba Serial Driver Help**

© 2011 Kepware Technologies

# Table of Contents

<b>Table of Contents</b> .....	<b>2</b>
<b>Toshiba Serial Driver Help</b> .....	<b>3</b>
<b>Overview</b> .....	<b>3</b>
<b>Device Setup</b> .....	<b>4</b>
<b>Modem Setup</b> .....	<b>4</b>
<b>Cable Diagram - EX100/200 PLCs</b> .....	<b>4</b>
<b>Cable Diagram - T1 PLCs</b> .....	<b>5</b>
<b>Cable Diagram - T2/T3 PLCs</b> .....	<b>5</b>
<b>Cable Diagram - Tosline S-20 SIF Interface</b> .....	<b>6</b>
<b>Data Types Description</b> .....	<b>9</b>
<b>Address Descriptions</b> .....	<b>10</b>
<b>EX100 Addressing</b> .....	<b>10</b>
<b>EX200 Addressing</b> .....	<b>10</b>
<b>EX500 Addressing</b> .....	<b>11</b>
<b>T1, T1 Super Addressing</b> .....	<b>12</b>
<b>T2 Addressing</b> .....	<b>13</b>
<b>T3, T3H Addressing</b> .....	<b>14</b>
<b>Error Descriptions</b> .....	<b>16</b>
<b>Address Validation</b> .....	<b>16</b>
Missing address.....	16
Device address '<address>' contains a syntax error.....	16
Address '<address>' is out of range for the specified device or register.....	16
Data Type '<type>' is not valid for device address '<address>'.....	17
Device address '<address>' is not supported by model '<model name>'.....	17
Device address '<address>' is Read Only.....	17
<b>Serial Communications</b> .....	<b>17</b>
COMn does not exist.....	17
Error opening COMn.....	18
COMn is in use by another application.....	18
Unable to set comm parameters on COMn.....	18
Communications error on '<channel name>' [<error mask>].....	18
<b>Device Status Messages</b> .....	<b>18</b>
Device '<device name>' is not responding.....	19
Unable to write to address '<address>' on device '<device name>'.....	19
<b>Index</b> .....	<b>20</b>

## Toshiba Serial Driver Help

---

Help version 1.014

### CONTENTS

#### [Overview](#)

What is the Toshiba Serial Driver?

#### [Device Setup](#)

How do I configure a specific device to work with this driver?

#### [Data Types Description](#)

What data types does this driver support?

#### [Address Descriptions](#)

How do I address a data location on a Toshiba device?

#### [Error Descriptions](#)

What error messages does the Toshiba Serial driver produce?

### Overview

---

The Toshiba Serial Driver provides an easy and reliable way to connect Toshiba Serial devices to OPC Client applications, including HMI, SCADA, Historian, MES, ERP and countless custom applications. It uses the Toshiba ASCII Computer Link protocol to communicate with the PLC. Before attempting to use the driver in an OPC server software project, users should understand the different data types and the addressing scheme. For more information, refer to [Data Types Description](#) and [Address Descriptions](#).

## Device Setup

---

### Supported Devices

EX100  
EX200  
T1  
T1 Super  
T2 PLCs  
T3 PLCs

### Communication Protocol

Toshiba ASCII Computer Link Protocol

### Supported Communication Parameters

Baud Rate: 1200, 2400, 9600, 19200, or 38400  
Parity: None, Even, or Odd  
Data Bits: 5, 6, 7 or 8  
Stop Bits: 1 or 2

### Device IDs

EX100: Up to 16 devices numbered from 0 to 15.  
EX200: Up to 10 devices numbered from 0 to 9.  
T1 and T2: Up to 32 devices numbered from 1 to 32.  
T3 and T3H: Up to 64 devices numbered from 1 to 64.

### Flow Control

When using an RS232/RS485 converter, the type of flow control that is required depends on the needs of the converter. Some converters do not require any flow control whereas others require RTS flow. Consult the converter's documentation to determine its flow requirements. An RS485 converter that provides automatic flow control is recommended.

**Note:** When using T1 devices, **RTS Always** should be specified.

### Ethernet Encapsulation

This driver supports Ethernet Encapsulation, which allows the driver to communicate with serial devices attached to an Ethernet network using a terminal server or device server. It may be invoked through the COM ID dialog in Channel Properties. For more information, refer to the OPC Server help file.

### Cable Connections

The T1 can be directly connected to the PC COM port using RS232 communications. The EX100, EX200 and T2 can be linked to the PC's RS232 interface through a RS232/RS422 converter. For connection information between the PLC and a RS232/RS422 converter, refer to the PLC manual.

[Cable Diagram - EX100/200 PLCs](#)

[Cable Diagram - T1 PLCs](#)

[Cable Diagram - T2/T3 PLCs](#)

[Cable Diagram - Tosline S-20 SIF Interface](#)

## Modem Setup

---

This driver supports modem functionality. For more information, please refer to the topic "Modem Support" in the OPC Server Help documentation.

## Cable Diagram - EX100/200 PLCs

---

### Toshiba EX100/200 Cable Pin Out

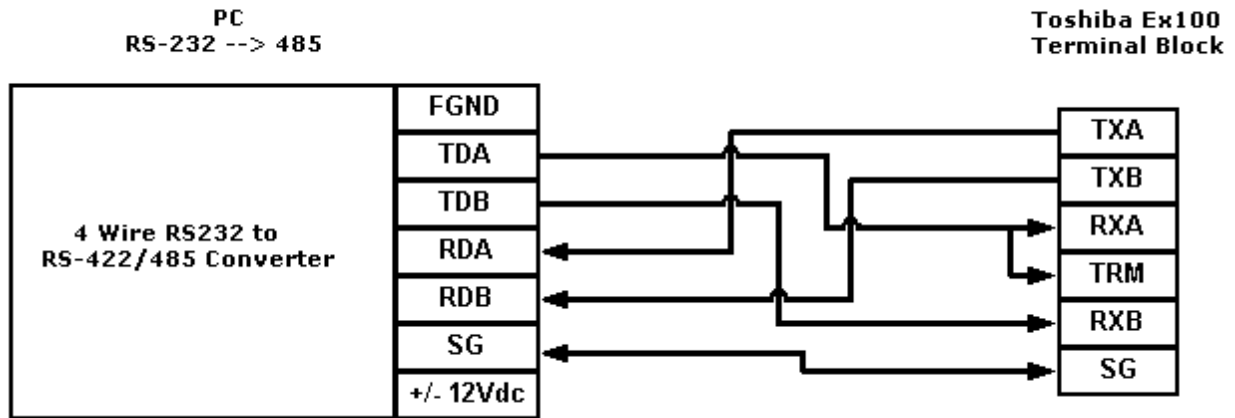

**Note:** This connection does not need a powered converter.

**Cable Diagram - T1 PLCs**

**Toshiba T1 Cable Pin Out**

DB9 RS232 Connector

1	CD
2	RXD
3	TXD
4	DTR
5	GND
6	DSR
7	RTS
8	CTS
9	FGND

8 Pos DIN Connector

5 Vdc	1
Gnd	2
5 Vdc	3
RTS	4
SG	5
TXD	6
CTS	7
RXD	8



**Cable Diagram - T2/T3 PLCs**

**Toshiba T2/T3 Cable Pin Out**

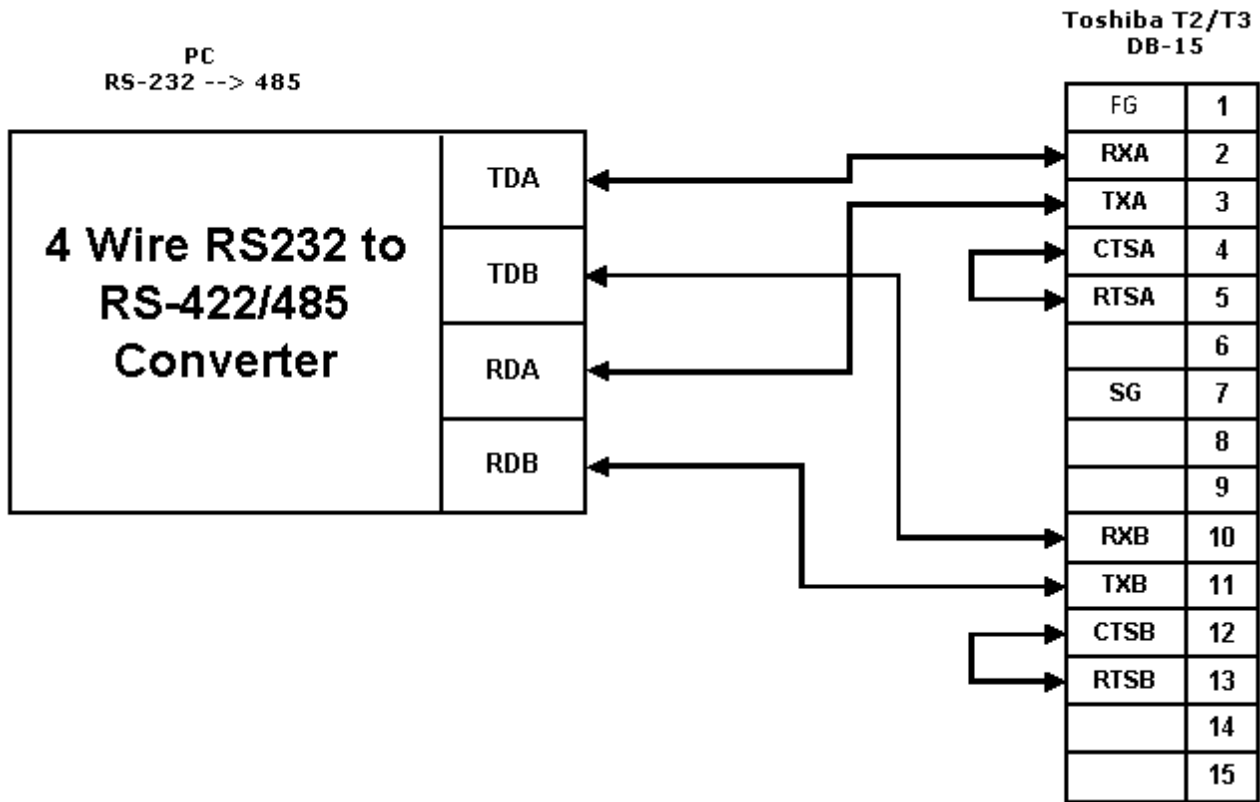

**Note:** This connection does not need a powered converter.

**Cable Diagram - Tosline S-20 SIF Interface**

**Toshiba S20 SIF Station**

The Tosline S20 SIF interface provides a fiber optic link to Toshiba PLCs using the Tosline S20 module. The interface between the PC and the S20 SIF module is RS-232.

**Note:** The S20 SIF must be assigned a station on the network. This station number must not match any other PLCs on the network.

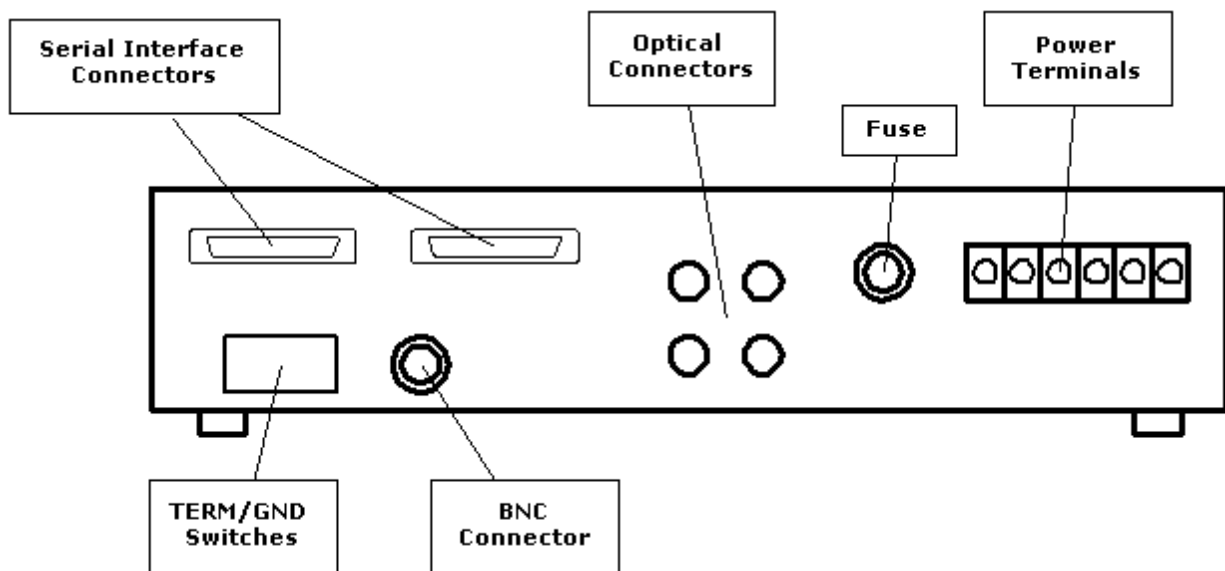

**Optical Connector Layout**

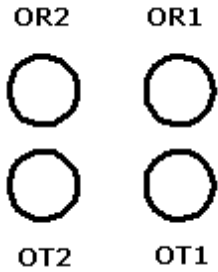

**Note:** The D-Sub 25 Pin female connectors are provided on the SIF station. The cable side connectors are attached as accessories. The pin out is DCE type.

#### Pin Assignment and Standard Connection from PC to S-20 SIF

SIF 20 Interface

Pin	Signal
2	TX
3	RX
4	RTS
5	CTS
6	DSR
7	SG
8	CD
20	DTR

Host PC

Signal	Pin
TX	2
RX	3
RTS	4
CTS	5
DSR	6
SG	7
CD	8
DTR	20

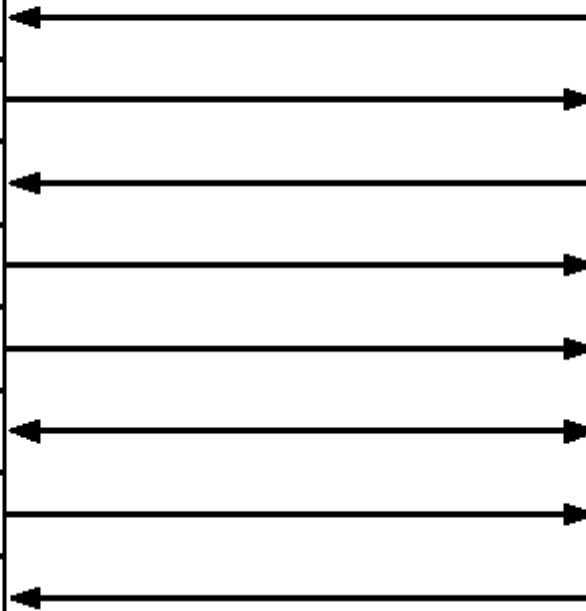

#### Cable Assignment for S-20 SIF to PLC

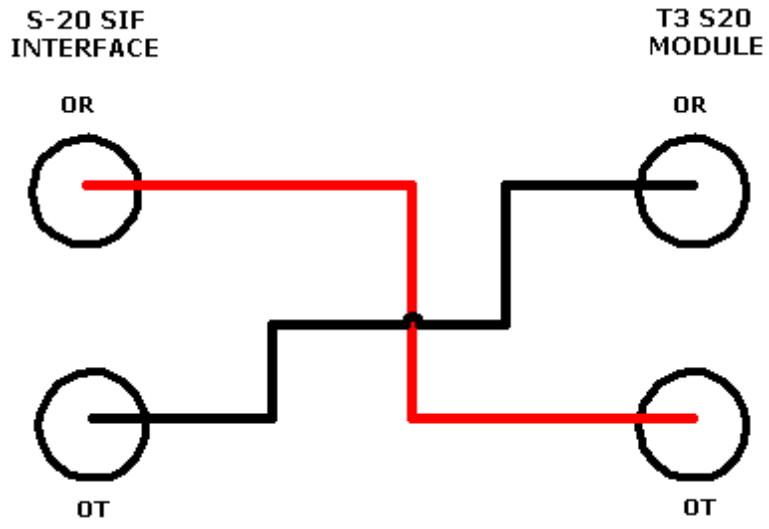

## Data Types Description

---

Data Type	Description
Boolean	Single bit
Word	Unsigned 16 bit value bit 0 is the least significant bit bit 15 the most significant bit
Short	Signed 16 bit value bit 0 is the least significant bit bit 14 the most significant bit bit 15 is the sign bit
DWord	Unsigned 32 bit value bit 0 is the least significant bit bit 31 the most significant bit
Long	Signed 32 bit value bit 0 is the least significant bit bit 30 the most significant bit bit 31 is the sign bit
Float	32 bit floating point value.  The driver interprets two consecutive registers as a floating point value by making the second register the high word and the first register the low word.
String	Null terminated ASCII string  This is supported on all models and includes HiLo LoHi byte order selection.

## Address Descriptions

Address specifications vary depending on the model in use. Select a link from the following list to obtain specific address information for the model of interest.

[EX100](#)

[EX200](#)

[EX500](#)

[T1, T1Super](#)

[T2](#)

[T3, T3H](#)

## EX100 Addressing

The default data types are shown in **bold**.

Address Type	Range	Data Type	Access
Input Devices	X00...X0F-X310...X31F	Boolean	Read/Write
Output Devices	Y00...Y0F-Y310...Y31F	Boolean	Read/Write
Input Registers	XW0-XW63	<b>Word</b> , Short	Read/Write
	XW0-XW62	DWord, Long, Float	
Output Registers	YW0-YW63	<b>Word</b> , Short	Read/Write
	YW0-YW62	DWord, Long, Float	
Auxiliary Devices	R00...R0F-R630...R63F	Boolean	Read/Write
Auxiliary Registers	RW0-RW63	<b>Word</b> , Short	Read/Write
	RW0-RW62	DWord, Long, Float	
Link Register Relays	Z00...Z0F-Z310...Z31F	Boolean	Read/Write
Link Registers	ZW0-ZW31	<b>Word</b> , Short	Read/Write
	ZW0-ZW30	DWord, Long, Float	
Counter Registers	C0-C95	<b>Word</b> , Short	Read/Write
Timer Registers	T0-T127	<b>Word</b> , Short	Read/Write
Data Memory	D0-D1535	<b>Word</b> , Short	Read/Write
	D0-D1534	DWord, Long, Float	
Data Memory As String with HiLo Byte Order	D0.2H-D1535.64H .Bit is string length, range 2 to 64 bytes.	<b>String</b>	Read/Write
Data Memory As String with LoHi Byte Order	D0.2L-D1535.64L .Bit is string length, range 2 to 64 bytes.	<b>String</b>	Read/Write

### String Support

The Toshiba Serial driver supports reading and writing Data registers as an ASCII string. When using Data registers for string data, each register will contain two bytes of ASCII data. The order of the ASCII data within a given register can be selected when the string is defined. The length of the string can be from 2 to 64 bytes and is entered in place of a bit number. The length must be entered as an even number. The byte order is specified by appending either a "H" or "L" to the address.

#### Examples

- To address a string starting at D200 with a length of 50 bytes and HiLo byte order, enter:  
D200.50H
- To address a string starting at D500 with a length of 38 bytes and LoHi byte order, enter:  
D500.38L

## EX200 Addressing

The default data types are shown in **bold**.

Address Type	Range	Data Type	Access
Input Devices	X00...X0F-X310...X31F	Boolean	Read/Write
Output Devices	Y00...Y0F-Y310...Y31F	Boolean	Read/Write
Input Registers	XW0-XW63	<b>Word</b> , Short	Read/Write
	XW0-XW62	DWord, Long, Float	
Output Registers	YW0-YW63	<b>Word</b> , Short	Read/Write
	YW0-YW62	DWord, Long, Float	
Auxiliary Devices	R00...R0F-R630...R63F	Boolean	Read/Write
Auxiliary Registers	RW0-RW63	<b>Word</b> , Short	Read/Write
	RW0-RW62	DWord, Long, Float	
Link Register Relays	Z00...Z0F-Z310...Z31F	Boolean	Read/Write
Link Registers	ZW0-ZW31	<b>Word</b> , Short	Read/Write
	ZW0-ZW30	DWord, Long, Float	
Counter Registers	C0-C95	<b>Word</b> , Short	Read/Write
Timer Registers	T0-T127	<b>Word</b> , Short	Read/Write
Data Memory	D0-D1535	<b>Word</b> , Short	Read/Write
	D0-D1534	DWord, Long, Float	
Data Memory As String with HiLo Byte Order	D0.2H-D1535.64H .Bit is string length, range 2 to 64 bytes.	<b>String</b>	Read/Write
Data Memory As String with LoHi Byte Order	D0.2L-D1535.64L .Bit is string length, range 2 to 64 bytes.	<b>String</b>	Read/Write

### String Support

The Toshiba Serial driver supports reading and writing Data registers as an ASCII string. When using Data registers for string data, each register will contain two bytes of ASCII data. The order of the ASCII data within a given register can be selected when the string is defined. The length of the string can be from 2 to 64 bytes and is entered in place of a bit number. The length must be entered as an even number. The byte order is specified by appending either a "H" or "L" to the address.

#### Examples

- To address a string starting at D200 with a length of 50 bytes and HiLo byte order, enter:  
D200.50H
- To address a string starting at D500 with a length of 38 bytes and LoHi byte order, enter:  
D500.38L

### EX500 Addressing

The default data types are shown in **bold**.

Address Type	Range	Data Type	Access
Input Devices	X00...X0F-X310...X31F	Boolean	Read/Write
Output Devices	Y00...Y0F-Y310...Y31F	Boolean	Read/Write
Input Registers	XW0-XW63	<b>Word</b> , Short	Read/Write
	XW0-XW62	DWord, Long, Float	
Output Registers	YW0-YW63	<b>Word</b> , Short	Read/Write
	YW0-YW62	DWord, Long, Float	
Auxiliary Devices	R00...R0F-R630...R63F	Boolean	Read/Write
Auxiliary Registers	RW0-RW63	<b>Word</b> , Short	Read/Write
	RW0-RW62	DWord, Long, Float	
Link Register Relays	Z00...Z0F-Z310...Z31F	Boolean	Read/Write
Link Registers	ZW0-ZW31	<b>Word</b> , Short	Read/Write

	ZW0-ZW30	DWord, Long, Float	
Counter Registers	C0-C95	<b>Word</b> , Short	Read/Write
Timer Registers	T0-T127	<b>Word</b> , Short	Read/Write
Data Memory	D0-D1535	<b>Word</b> , Short	Read/Write
	D0-D1534	DWord, Long, Float	
Data Memory As String with HiLo Byte Order	D0.2H-D1535.64H .Bit is string length, range 2 to 64 bytes.	<b>String</b>	Read/Write
Data Memory As String with LoHi Byte Order	D0.2L-D1535.64L .Bit is string length, range 2 to 64 bytes.	<b>String</b>	Read/Write

### String Support

The Toshiba Serial driver supports reading and writing Data registers as an ASCII string. When using Data registers for string data, each register will contain two bytes of ASCII data. The order of the ASCII data within a given register can be selected when the string is defined. The length of the string can be from 2 to 64 bytes and is entered in place of a bit number. The length must be entered as an even number. The byte order is specified by appending either a "H" or "L" to the address.

#### Examples

1. To address a string starting at D200 with a length of 50 bytes and HiLo byte order, enter:  
D200.50H

2. To address a string starting at D500 with a length of 38 bytes and LoHi byte order, enter:  
D500.38L

### T1, T1 Super Addressing

The default data types are shown in **bold**.

Address Type	Range	Data Type	Access
Input Devices	X00...X0F-X310...X31F	Boolean	Read/Write
Output Devices	Y00...Y0F-Y310...Y31F	Boolean	Read/Write
Input Registers	XW0-XW63	<b>Word</b> , Short	Read/Write
	XW0-XW62	DWord, Long, Float	
Output Registers	YW0-YW63	<b>Word</b> , Short	Read/Write
	YW0-YW62	DWord, Long, Float	
Auxiliary Devices	R00...R0F-R2550...R255F	Boolean	Read/Write
Auxiliary Registers	RW0-RW255	<b>Word</b> , Short	Read/Write
	RW0-RW254	DWord, Long, Float	
Special Devices	S00...S0F-S630...S63F	Boolean	Read/Write
Special Registers	SW0-SW63	<b>Word</b> , Short	Read Only
	SW0-SW62	DWord, Long, Float	
Counter Registers	C0-C255	<b>Word</b> , Short	Read/Write
Counter Devices	C.0-C.255	Boolean	Read Only
Timer Registers	T0-T63	<b>Word</b> , Short	Read/Write
Timer Devices	T.0-T.63	Boolean	Read Only
Data Memory	D0-D4095	<b>Word</b> , Short	Read/Write
	D0-D4094	DWord, Long, Float	
Data Memory As String with HiLo Byte Order	D0.2H-D4095.64H .Bit is string length, range 2 to 64 bytes.	<b>String</b>	Read/Write
Data Memory As String with LoHi Byte Order	D0.2L-D4095.64L .Bit is string length, range 2 to 64 bytes.	<b>String</b>	Read/Write

## String Support

The Toshiba Serial driver supports reading and writing Data registers as an ASCII string. When using Data registers for string data, each register will contain two bytes of ASCII data. The order of the ASCII data within a given register can be selected when the string is defined. The length of the string can be from 2 to 64 bytes and is entered in place of a bit number. The length must be entered as an even number. The byte order is specified by appending either a "H" or "L" to the address.

### Examples

1. To address a string starting at D200 with a length of 50 bytes and HiLo byte order, enter:  
D200.50H

2. To address a string starting at D500 with a length of 38 bytes and LoHi byte order, enter:  
D500.38L

## T2 Addressing

The default data types are shown in **bold**.

Address Type	Range	Data Type	Access
Input Devices	X00...X0F-X630...X63F	Boolean	Read/Write
Direct Input Devices	I00...I0F-I630...I63F	Boolean	Read Only
Output Devices	Y00...Y0F-Y630...Y63F	Boolean	Read/Write
Direct Output Devices	O00...O0F-O630...O63F	Boolean	Read/Write
Input Registers	XW0-XW63	<b>Word</b> , Short	Read/Write
	XW0-XW62	DWord, Long, Float	
Direct Input Registers	IW0-IW63	<b>Word</b> , Short	Read/Write
	IW0-IW62	DWord, Long, Float	
Output Registers	YW0-YW63	<b>Word</b> , Short	Read/Write
	YW0-YW62	DWord, Long, Float	
Direct Output Registers	OW0-OW63	<b>Word</b> , Short	Read/Write
	OW0-OW62	DWord, Long, Float	
Link Relays	L00...L0F-L2550...L255F	Boolean	Read/Write
Link Registers	LW0-LW255	<b>Word</b> , Short	Read/Write
	LW0-LW254	DWord, Long, Float	
Link Registers	W0-W1023	<b>Word</b> , Short	Read/Write
	W0-W1022	DWord, Long, Float	
Link Register Relays	Z00...Z0F-Z5110...Z511F	Boolean	Read/Write
File Registers	F0-F1023	<b>Word</b> , Short	Read/Write
	F0-F1022	DWord, Long, Float	
Auxiliary Devices	R00...R0F-R1270...R127F	Boolean	Read/Write
Auxiliary Registers	RW0-RW127	<b>Word</b> , Short	Read/Write
	RW0-RW126	DWord, Long, Float	
Special Devices	S00...S0F-S2550...S255F	Boolean	Read/Write
Special Registers	SW0-SW255	<b>Word</b> , Short	Read Only
	SW0-SW254	DWord, Long, Float	
Counter Registers	C0-C255	<b>Word</b> , Short	Read/Write
Counter Devices	C.0-C.255	Boolean	Read Only
Timer Registers	T0-T255	<b>Word</b> , Short	Read/Write
Timer Devices	T.0-T.255	Boolean	Read Only
Data Memory	D0-D4095	<b>Word</b> , Short	Read/Write
	D0-D4094	DWord, Long, Float	

Data Memory As String with HiLo Byte Order	D0.2H-D4095.64H .Bit is string length, range 2 to 64 bytes.	<b>String</b>	Read/Write
Data Memory As String with LoHi Byte Order	D0.2L-D4095.64L .Bit is string length, range 2 to 64 bytes.	<b>String</b>	Read/Write

### String Support

The Toshiba Serial driver supports reading and writing Data registers as an ASCII string. When using Data registers for string data, each register will contain two bytes of ASCII data. The order of the ASCII data within a given register can be selected when the string is defined. The length of the string can be from 2 to 64 bytes and is entered in place of a bit number. The length must be entered as an even number. The byte order is specified by appending either a "H" or "L" to the address.

#### Examples

- To address a string starting at D200 with a length of 50 bytes and HiLo byte order, enter:  
D200.50H
- To address a string starting at D500 with a length of 38 bytes and LoHi byte order, enter:  
D500.38L

### T3, T3H Addressing

The default data types are shown in **bold**.

Address Type	Range	Data Type	Access
Input Devices	X00...X0F-X5110...X511F	Boolean	Read/Write
Direct Input Devices	I00...I0F-I5110...I511F	Boolean	Read Only
Output Devices	Y00...Y0F-Y5110...Y511F	Boolean	Read/Write
Direct Output Devices	O00...O0F-O5110...O511F	Boolean	Read/Write
Input Registers	XW0-XW511	<b>Word</b> , Short	Read/Write
	XW0-XW510	DWord, Long, Float	
Direct Input Registers	IW0-IW511	<b>Word</b> , Short	Read/Write
	IW0-IW510	DWord, Long, Float	
Output Registers	YW0-YW511	<b>Word</b> , Short	Read/Write
	YW0-YW510	DWord, Long, Float	
Direct Output Registers	OW0-OW511	<b>Word</b> , Short	Read/Write
	OW0-OW510	DWord, Long, Float	
Link Relays	L00...L0F-L2550...L255F	Boolean	Read/Write
Link Registers	LW0-LW255	<b>Word</b> , Short	Read/Write
	LW0-LW254	DWord, Long, Float	
Link Registers	W0-W2047	<b>Word</b> , Short	Read/Write
	W0-W2046	DWord, Long, Float	
Link Register Relays	Z00...Z0F-Z9990...Z999F	Boolean	Read/Write
File Registers	F0-F8191	<b>Word</b> , Short	Read/Write
	F0-F8190	DWord, Long, Float	
Auxiliary Devices	R00...R0F-R9990...R999F	Boolean	Read/Write
Auxiliary Registers	RW0-RW999	<b>Word</b> , Short	Read/Write
	RW0-RW998	DWord, Long, Float	
Special Devices	S00...S0F-S2550...S255F	Boolean	Read/Write
Special Registers	SW0-SW255	<b>Word</b> , Short	Read Only
	SW0-SW254	DWord, Long, Float	
Counter Registers	C0-C511	<b>Word</b> , Short	Read/Write

Counter Devices	C.0-C.511	Boolean	Read Only
Timer Registers	T0-T999	<b>Word</b> , Short	Read/Write
Timer Devices	T.0-T.999	Boolean	Read Only
Data Memory	D0-D8191 D0-D8190	<b>Word</b> , Short DWord, Long, Float	Read/Write
Data Memory As String with HiLo Byte Order	D0.2H-D8191.64H .Bit is string length, range 2 to 64 bytes.	<b>String</b>	Read/Write
Data Memory As String with LoHi Byte Order	D0.2L-D8191.64L .Bit is string length, range 2 to 64 bytes.	<b>String</b>	Read/Write

### String Support

The Toshiba Serial driver supports reading and writing Data registers as an ASCII string. When using Data registers for string data, each register will contain two bytes of ASCII data. The order of the ASCII data within a given register can be selected when the string is defined. The length of the string can be from 2 to 64 bytes and is entered in place of a bit number. The length must be entered as an even number. The byte order is specified by appending either a "H" or "L" to the address.

### Examples

1. To address a string starting at D200 with a length of 50 bytes and HiLo byte order, enter:  
D200.50H
2. To address a string starting at D500 with a length of 38 bytes and LoHi byte order, enter:  
D500.38L

## Error Descriptions

---

The following error/warning messages may be generated. Click on the link for a description of the message.

### Address Validation

#### [Missing address](#)

[Device address '<address>' contains a syntax error](#)

[Address '<address>' is out of range for the specified device or register](#)

[Device address '<address>' is not supported by model '<model name>'](#)

[Data Type '<type>' is not valid for device address '<address>'](#)

[Device address '<address>' is Read Only](#)

### Serial Communications

#### [COMn does not exist](#)

[Error opening COMn](#)

[COMn is in use by another application](#)

[Unable to set comm parameters on COMn](#)

[Communications error on '<channel name>' \[<error mask>\]](#)

### Device Status Messages

[Device '<device name>' is not responding](#)

[Unable to write to '<address>' on device '<device name>'](#)

## Address Validation

---

The following error/warning messages may be generated. Click on the link for a description of the message.

### Address Validation

#### [Missing address](#)

[Device address '<address>' contains a syntax error](#)

[Address '<address>' is out of range for the specified device or register](#)

[Device address '<address>' is not supported by model '<model name>'](#)

[Data Type '<type>' is not valid for device address '<address>'](#)

[Device address '<address>' is Read Only](#)

## Missing address

---

### Error Type:

Warning

### Possible Cause:

A tag address that has been specified dynamically has no length.

### Solution:

Re-enter the address in the client application.

## Device address '<address>' contains a syntax error

---

### Error Type:

Warning

### Possible Cause:

A tag address that has been specified dynamically contains one or more invalid characters.

### Solution:

Re-enter the address in the client application.

## Address '<address>' is out of range for the specified device or register

---

### Error Type:

Warning

### Possible Cause:

A tag address that has been specified dynamically references a location that is beyond the range of supported locations for the device.

**Solution:**

Verify the address is correct; if it is not, re-enter it in the client application.

---

**Data Type '<type>' is not valid for device address '<address>'**

---

**Error Type:**

Warning

**Possible Cause:**

A tag address that has been specified dynamically has been assigned an invalid data type.

**Solution:**

Modify the requested data type in the client application.

---

**Device address '<address>' is not supported by model '<model name>'**

---

**Error Type:**

Warning

**Possible Cause:**

A tag address that has been specified dynamically references a location that is valid for the communications protocol but not supported by the target device.

**Solution:**

Verify the address is correct; if it is not, re-enter it in the client application. Also verify the selected model name for the device is correct.

---

**Device address '<address>' is Read Only**

---

**Error Type:**

Warning

**Possible Cause:**

A tag address that has been specified dynamically has a requested access mode that is not compatible with what the device supports for that address.

**Solution:**

Change the access mode in the client application.

---

**Serial Communications**

---

The following error/warning messages may be generated. Click on the link for a description of the message.

**Serial Communications**

[COMn does not exist](#)

[Error opening COMn](#)

[COMn is in use by another application](#)

[Unable to set comm parameters on COMn](#)

[Communications error on '<channel name>' \[<error mask>\]](#)

---

**COMn does not exist**

---

**Error Type:**

Fatal

**Possible Cause:**

The specified COM port is not present on the target computer.

**Solution:**

Verify that the proper COM port has been selected.

## Error opening COMn

---

**Error Type:**

Fatal

**Possible Cause:**

The specified COM port could not be opened due an internal hardware or software problem on the target computer.

**Solution:**

Verify that the COM port is functional and may be accessed by other Windows applications.

## COMn is in use by another application

---

**Error Type:**

Fatal

**Possible Cause:**

The serial port assigned to a device is being used by another application.

**Solution:**

Verify that the correct port has been assigned to the channel.

## Unable to set comm parameters on COMn

---

**Error Type:**

Fatal

**Possible Cause:**

The serial parameters for the specified COM port are not valid.

**Solution:**

Verify the serial parameters and make any necessary changes.

## Communications error on '<channel name>' [<error mask>]

---

**Error Type:**

Serious

**Error Mask Definitions:**

**B** = Hardware break detected.

**F** = Framing error.

**E** = I/O error.

**O** = Character buffer overrun.

**R** = RX buffer overrun.

**P** = Received byte parity error.

**T** = TX buffer full.

**Possible Cause:**

1. The serial connection between the device and the Host PC is bad.
2. The communications parameters for the serial connection are incorrect.

**Solution:**

1. Verify the cabling between the PC and the PLC device.
2. Verify that the specified communications parameters match those of the device.

## Device Status Messages

---

The following error/warning messages may be generated. Click on the link for a description of the message.

**Device Status Messages**

[Device '<device name>' is not responding](#)

[Unable to write to '<address>' on device '<device name>'](#)

---

**Device '<device name>' is not responding**

---

**Error Type:**

Serious

**Possible Cause:**

1. The named device may not be connected to the PLC network.
2. The named device may have been assigned an incorrect Network ID.

**Solution:**

1. Check the PLC network connections.
2. Verify the Network ID given to the named device matches that of the actual device.

---

**Unable to write to address '<address>' on device '<device name>'**

---

**Error Type:**

Serious

**Possible Cause:**

1. The serial connection between the device and the Host PC is broken.
2. The communications parameters for the serial connection are incorrect.
3. The named device may have been assigned an incorrect Network ID.

**Solution:**

1. Verify the cabling between the PC and the PLC device.
2. Verify the specified communications parameters match those of the device.
3. Verify that the Network ID given to the named device matches that of the actual device.

# Index

## A

Address '<address>' is out of range for the specified device or register.....	16
Address Descriptions.....	10
Address Validation.....	16

## B

Boolean.....	9
--------------	---

## C

Cable Connections.....	4
Cable Diagram - EX100/200 PLCs.....	4
Cable Diagram - T1 PLCs.....	5
Cable Diagram - T2/T3 PLCs.....	5
Cable Diagram - Tosline S-20 SIF Interface.....	6
Communication Parameters.....	4
Communication Protocol.....	4
Communications error on '<channel name>' [<error mask>].....	18
COMn does not exist.....	17
COMn is in use by another application.....	18

## D

Data Type '<type>' is not valid for device address '<address>'.....	17
Data Types Description.....	9
Device '<device name>' not responding.....	19
Device address '<address>' contains a syntax error.....	16
Device address '<address>' is not supported by model '<model name>'.....	17
Device address '<address>' is Read Only.....	17
Device ID.....	4
Device Setup.....	4
Device Status Messages.....	18
DWord.....	9

## E

Error Descriptions.....	16
Error opening COMn.....	18
EX100 Addressing.....	10
EX200 Addressing.....	10
EX500 Addressing.....	11

<b>F</b>	
Framing.....	18
<b>L</b>	
Long.....	9
<b>M</b>	
Mask.....	18
Missing address.....	16
Modem Setup.....	4
<b>O</b>	
Overrun.....	18
Overview.....	3
<b>P</b>	
Parameters.....	4
Parity.....	18
Protocol.....	4
<b>S</b>	
Serial Communications.....	17
Short.....	9
<b>T</b>	
T1, T1 Super Addressing.....	12
T2 Addressing.....	13
T3, T3H Addressing.....	14
Tosline S20 SIF Interface.....	6
<b>U</b>	
Unable to set comm parameters on COMn.....	18
Unable to write to address '<address>' on device '<device name>'.....	19
<b>W</b>	
Word.....	9