



RS232/CMOS to RS422/RS485 Converter converts RS232/CMOS lines to balanced RS422 or RS485 signals. RS232/CMOS to RS422/RS485 converter is available in two models, CNV-01 and CNV-02-B.

Power is isolated from communication ports in CNV-01 model, whereas communication ports are not isolated. The converter is a port-powered (line-powered: RXD+RTS+CTS) or externally powered. In case of point to point communication and if the cable length is less than or equal to 2 mtr. at RS232 side, then external power supply is not needed. This unit takes less than 4mA to operate plus load current. Applications which require a large load current, external +24VDC power supply on the terminal strip is required. (NOTE: CMOS signals are not available with CNV-01 model) Both the communication ports as well as power is isolated in CNV-02-B model. This model operates on external 24VDC supply.

The unit has DB9 female connector on RS232/CMOS side and PBT on RS422/RS485 side. RS485 port has 4-wire with signal ground system and can also be made as 2-wire RS232-RS485 converter with signal ground system.

Specifications

Power Supply :	24 VDC +/- 10 %, 80 mA max. Isolation between communication ports and power supply through DC-DC coupler is 1KV.
Communication :	Two ports as follows: COM1 : RS232/CMOS COM2 : RS422 / RS485 Isolation between communication ports through Opto-isolation is 1KV for 1 minute.
Data Rates :	Up to 115.2 kbps.
Distance :	Externally powered units transmit up to 4000ft (1200m) at RS485 side (Less with port powering)
Temperature :	Operating: 0 to 60 °C Storage: - 40 to 90 °C
Humidity :	10% to 90% (Non condensing)
Immunity to ESD :	Level 3 as per IEC1000-4-2
Immunity to Transients :	Level 3 as per IEC1000-4-4
Radiated Susceptibility :	Level 3 as per IEC1000-4-3
Emissions :	EN55011 CISPR A
Certifications :	CE and CSA
Dimensions :	101mm (L) X 40mm (D) X 51mm (W) (DIN RAIL mounting)
Mounting :	Back Panel DIN Rail
Weight :	125 g approximately

The unit has

- a) DB9 Female connector (1 no.)
- b) Terminal blocks (2 nos.)
- c) Switches for different settings (4 nos.)

RS232/CMOS Port:

Connector: DB-9 female
Signal: Passes through pins 3 (RS232 RXD/CMOS RXD), 2 (RS232 TXD) and 9 (CMOS TXD) Pins 7 (RTS) and 8 (CTS) are tied together.
Pins 4 (DTR) and 6 (DSR) and 1(CD) are tied together.

RS232/CMOS port pin outs are as follows:

PIN #	SIGNAL
01	CD
02	RS232 TXD
03	RS232 RXD/CMOS RXD
04	DTR
05	SG
06	DSR
07	RTS
08	CTS
09	CMOS TXD

RS422/RS485 Port:

Connector: PBT
Signals: 2-wire RS485 half duplex, or 4-wire RS485 full duplex ,
4-wire RS422 full duplex depending on switch configuration.

RS422/RS485 port pin outs are as follows:

PI N	SIGNALS
01	TX+ (Also referred as TXA)
02	TX- (Also referred as TXB)
03	RX+ (Also referred as RXA)
04	RX- (Also referred as RXB)
05	SG (Signal Ground)

RS422/RS485 Continued....

In case of 2-wire RS485, Automatic direction control circuit enables driver when transmitting and disables receiver. Direction control can be automatic or controlled externally using handshake line (RTS). During marking or idle state, the RS485 driver is disabled and data lines are held by the 1k ohm pull up & pull down resistors.

Termination of 180 ohm can be used by setting switch 4 (termination) to ON position or any other value of termination can be used by connecting it between RX+ & RX- & switch 4 (termination) set to OFF.

Switch settings:

There are 4 switches for setting:

- 1. 4-wire/2-wire configuration,
- 2. RS485 / RS422 configuration,
- 3. Automatic/External direction control,
- 4. With/Without Termination

Following table shows switch positions for selection of the above parameters

Switch #	ON	OFF
1	2 Wire	4 Wire
2	RS485 Selection	RS422 Selection
3	External Direction Control	Automatic Direction Control
4	With Termination	Without Termination

4-WIRE RS422 FULL DUPLEX

This communication mode is generally used for point-to-point communication over long distances with better noise immunity than RS232/CMOS. The RS422 driver and receiver are always enabled to allow full duplex communications. To achieve proper operations there must be a pair of wires dedicated to the driver, a pair dedicated to the receiver and a ground reference wire for a total of 5 lines.

To set the converter for 4-wire RS422, Set switch 1 and switch 2 in OFF position. Set switch 3 (Direction Ctrl External/Direction Ctrl Automatic) in OFF position. Set switch 4 (Termination) in ON position if 180E termination is used else set it to OFF. If termination value is other than 180E then connect it between RX+ & RX- & set switch4 (Termination) in OFF position

No Termination		With Termination	
S/W	Position	S/W	Position
1	OFF	1	OFF
2	OFF	2	OFF
3	OFF	3	OFF
4	OFF	4	ON

Connect RX+ to TX+ and RX- to TX-, at both the ends and signal ground to signal ground.
DB9 Serial Port Connection

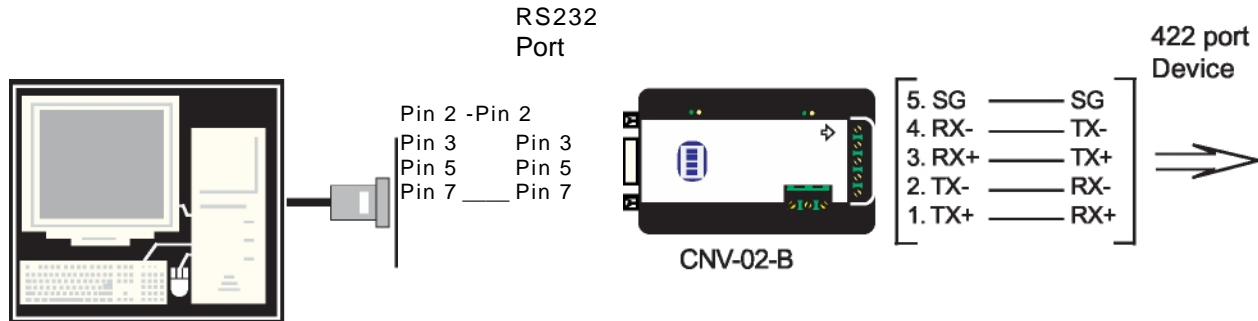

Figure 1: 4-Wire RS422 Full Duplex Diagram

2-WIRE RS485 HALF DUPLEX

This communication mode is used to connect several RS485 devices to the same network with minimum number of wires when only one unit talks at a time. The RS485 driver is automatically enabled during each spacing state on the RS232/CMOS side. During the marking or idle state RS485 driver is disabled and the data lines are held in the marking state by the 1K Ohm pull up and pull down resistors.

To set the converter for 2-wire RS485 half duplex, set switch 1 and switch 2 in ON position. If automatic direction control is required then set switch 3 in OFF position. If external direction control is required then set switch 3 in ON position. Set switch 4(Termination) in ON position if 180E termination is used else set it to OFF. If termination value is other than 180E then connect it between RX+ & RX- & switch 4 in OFF position.

2-WIRE RS485 HALF DUPLEX continued

Auto-Direction Control No Termination		Auto-Direction Control With Termination		Ext-Direction Control No Termination		Ext-Direction Control With Termination	
S/W	Position	S/W	Position	S/W	Position	S/W	Position
1	ON	1	ON	1	ON	1	ON
2	ON	2	ON	2	ON	2	ON
3	OFF	3	OFF	3	ON	3	ON
4	OFF	4	ON	4	OFF	4	ON

Follow the wiring diagram in Figure 2 to connect the converter to 2-wire half-duplex network. For 2 wire communication, consider TX+ as (A) & connect it to network's (A), similarly consider TX- as (B) & connect it to network's (B).

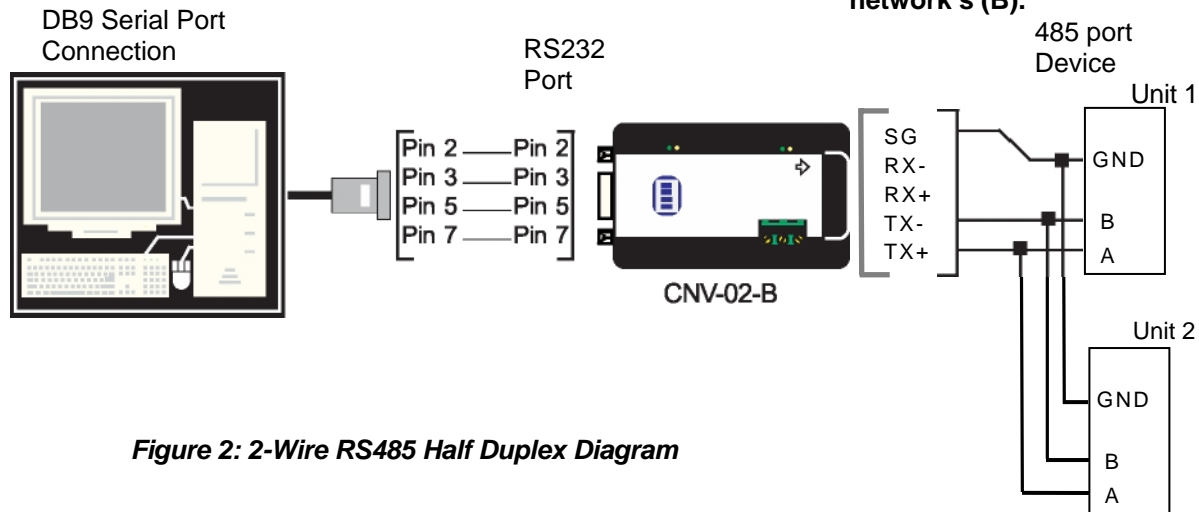

Figure 2: 2-Wire RS485 Half Duplex Diagram

Note-1: For CNV-01 and CNV-02 (Old versions) :

To connect the converter to 2-wire half-duplex network. Short (TX+ & RX+), consider this as (A) & connect it to network's (A). Short (TX- & RX-), consider this as (B) & connect it to network's (B).

Note-2: For CNV-02-B (New Version):

This model does not required shorting of "TX+ & RX+" and "TX- & RX-" for two wire RS485 configuration. This is advantage over old version models.

This communication mode is used to connect several RS485 devices in master/slave fashion, where only one unit (slave) talks at a time. The RS485 driver is automatically enabled during each spacing state on the RS232/CMOS side. During the marking or idle state RS485 driver is disabled and the data lines are held in the marking state by the 1K Ohm pull up and pull down resistors.

4-WIRE RS485 FULL DUPLEX

To set the converter to 4-wire RS485 full duplex, set switch 1 in OFF position. Set switch 2 in ON. Set switch 3 in OFF position if automatic direction control is required else for external direction control set it to ON position. Set switch 4 in ON position if 180E termination is used else set it to OFF. If termination value is other than 180E then connect it between RX+ & RX- & set switch 4 in OFF position.

Auto-Direction Control No Termination		Auto-Direction Control With Termination		Ext-Direction Control No Termination		Ext-Direction Control With Termination	
S/W	Position	S/W	Position	S/W	Position	S/W	Position
1	OFF	1	OFF	1	OFF	1	OFF
2	ON	2	ON	2	ON	2	ON
3	OFF	3	OFF	3	ON	3	ON
4	OFF	4	ON	4	OFF	4	ON

Follow the wiring diagram in Figure 3 to connect the converter to 4-wire full-duplex network. Connect TX +(TXA) to RX+ (RXA), TX- (TXB) to RX- (RXB) at both the ends and a ground wire must be connected between all the units. When multiple slaves are on the same network, the connection between the master and each slave must be same as shown in Figure3. This will cause all the slaves to have their transmitters and receivers connected & not allow communication between the slaves themselves.

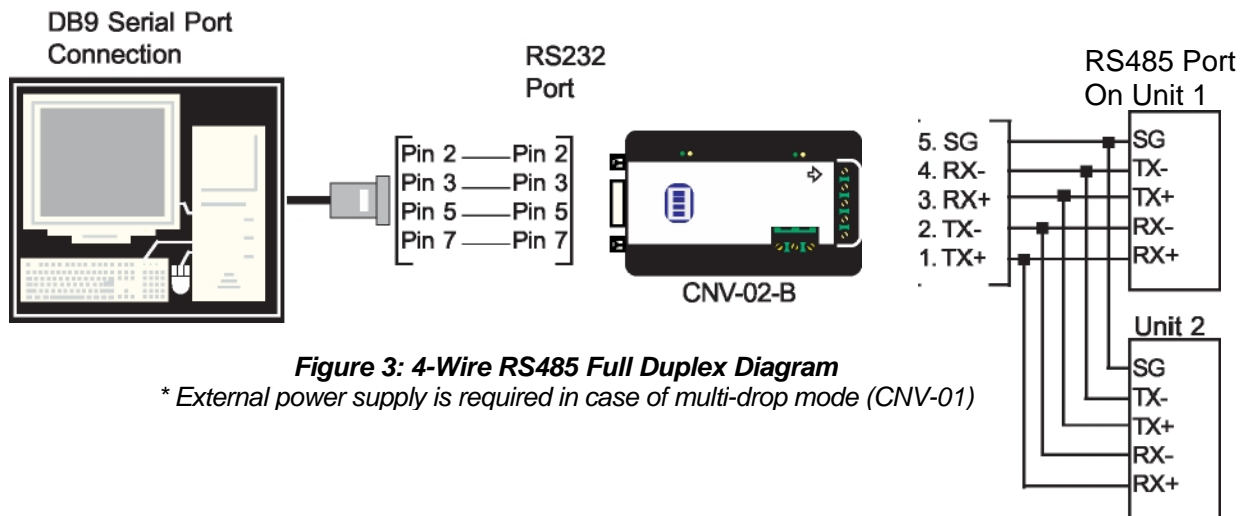

Figure 3: 4-Wire RS485 Full Duplex Diagram

* External power supply is required in case of multi-drop mode (CNV-01)

Note: Some PC based softwares require RTS & CTS and DTR & DSR lines shorted for proper communication. In such a cases it is recommend to use 9 pin to 9 pin cable at RS232 end. RTS & CTS and DTR & DSR are internally shorted in the converter.

TOSHIBA INTERNATIONAL CORPORATION

13131 West Little York Rd.
Houston, TX. 77041
www.tic.toshiba.com

Tel. 713-466-0277 Fax. 713-466-8773
US 800-231-1412 Canada 800-872-2192
Mexico 800-527-1204