

PROGRAMMABLE CONTROLLER

T2/EX100

Computer Link Module

CL11

User' s Guide

Thank you for purchasing the Computer Link Module (CL11) for Toshiba' s Programmable Controller T2/EX100. Please read this guide thoroughly to confirm the items you received, and to understand the functions of this product.

Unpacking Confirmation

Confirm that the product codes printed on the package and printed on the product are the same as that which you ordered. This package contains the following items.

CL11 (product code: EX10*MCL11)	1
Terminating resistor (1/2 W• 120 Ω)	1
Terminating resistors (1/2 W• 220 Ω)	4
User' s guide (this guide)	1

1. Overview

The Computer Link module (CL11) is used to link T2 or EX100 with a host computer for data exchange. The CL11 can be mounted on any I/O slot of T2 or EX100.

The CL11 has one port of RS-485 interface for connecting a host computer.

For exchanging data, the EX100' s Computer Link Protocol is used. In this protocol, the host computer initiates the communication. When the CL11 receives a request message issued from the host computer, the CL11 will perform the processing according to the request, then return the response message to the host computer.

2. System Configuration

Up to 32 CL11s can be connected to a single host computer on the RS-485 communication line.

1 to 1 configuration

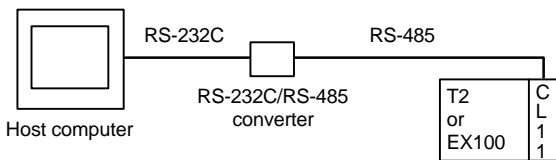

1 to N configuration

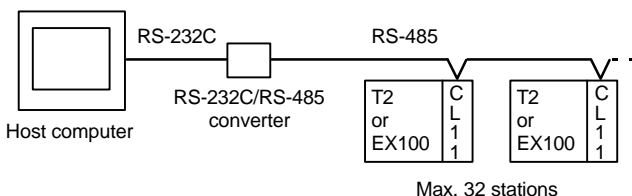

Safety Precautions

Prior to setting-up, operation and maintenance of this product, read this guide and T2 or EX100 related manuals thoroughly and follow the safety precautions.

The safety precautions are classified depending on the level as follows.

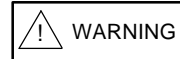

WARNING

Indicates a potentially hazardous situation which, if not avoided, could result in death or serious injury.



CAUTION

Indicates a potentially hazardous situation which, if not avoided, may result in minor or moderate injury. It may also be used to alert against unsafe practices.

WARNING

- Configure the emergency stop circuits and important inter-lock circuits in external of the PLC (T2 or EX100). Otherwise, it will cause serious damage to the controlled system in case of PLC or CL11 failure.

CAUTION

- Use the PLC (T2 or EX100) under the specified environmental condition described on the PLC' s manual. Otherwise, it may cause electrical shock, fire or PLC malfunction.
- Install the PLC and the CL11 according to the instructions described on the PLC' s manual.
- Prevent from entering wire scraps or other debris into the PLC and the CL11. Otherwise, it may case fire, PLC failure or malfunction.
- Turn off power to the PLC before mounting or removing the CL11.
- Do not disassemble or modify the CL11. Otherwise it may cause fire, failure or malfunction.
- CL11 is the dedicated module for T2 or EX100. Do not use the CL11 for other purpose.

3. External Feature and Switch Settings

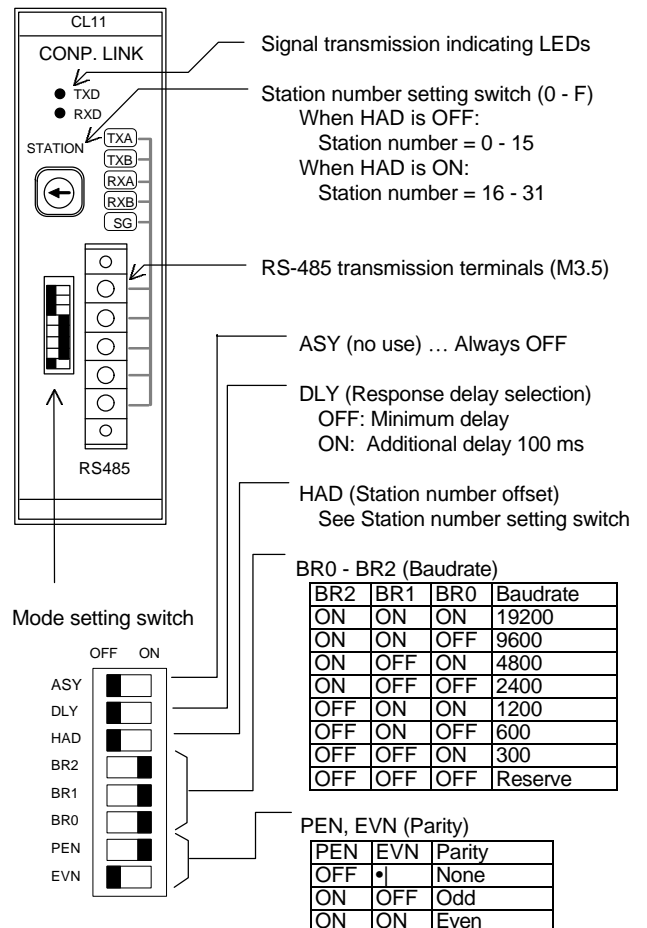

4. Specifications

Item	Specifications
I/O allocation	OPT (option module)
Protocol	EX100 Computer Link protocol (see Note)
Station number	0 to 31 (switch setting)
Interface	Conforms to RS-485
Number of channels	1 channel
Transmission mode	Half-duplex, 4-wire system
Signal polarity	Potential of start-bit: RXA < RAB, TXA < TXB
Synchronizing	Start-stop system (asynchronous)
Topology	Bus (multi-drop)
Transmission rate	300/600/1200/2400/4800/9600/19200 bps (switch setting)
Distance	Max. 1 km
Transmission code	ASCII
Data bit length	8 bits (fixed)
Stop bit	1 bit (fixed)
Parity	Even/odd/none (switch setting)
Error check	Parity, checksum

Note:

The CL11 supports the EX100's Computer Link protocol (message format and commands) independent of the PLC (T2 or EX100) used with. Note that the EX100's Computer Link protocol is different from the T-series Computer Link protocol. For details of the EX100's Computer Link protocol, refer to **EX100 Computer Link Function User's Manual?**. Depending on the PLC (T2 or EX100) used with, the operation conditions of the CL11 are different. See sections 6 and 7 below. assigned to **S014C**, and followed by this order. This status flag comes ON when the corresponding CL11 is not normal. (no response or hardware error)

6. When Using With T2

Operation conditions:

- (1) T2 CPU version 1.2 or later is required.
- (2) The maximum number of the CL11s on a T2 is 4.
- (3) The EX100's Computer Link protocol is used for the CL11. Note that the protocol is different from that of T2 CPU's built-in Computer Link function.
- (4) The following 3 types of commands are available among the EX100's Computer Link commands.

DR (Register/device data read)

DW (Register/device data write)

ST (Status read)

For other commands, the error response will be returned.

- (5) The types of registers and the address ranges that can be accessed by the **DR** or **DW** command are as follows. For other requests, the error response will be returned.

X/Y	0000 to 031F	XW/YW	00 to 63
R	0000 to 063F	RW	00 to 63
Z	0000 to 031F	ZW(W)	00 to 31
		T	000 to 127
		C	00 to 95
		D	0000 to 1535

Quick response mode:

By setting the T2's special device **S0148** to ON, The quick response mode is selected. In this mode, T2 will stop the scanning immediately and perform the CL11 service when T2 receives the CL11's request.

By using this mode, quick communication response is achieved. However, note that the scan synchronization of the accessed data is not guaranteed.

CL11 status flags:

CL11's operation status is reflected on the T2's special devices **S014C** to **S014F**. The CL11 that is mounted closest to the T2 CPU is

5. Connections

The following diagrams show the signal connections of sample configurations. Terminating resistors are supplied with the CL11.

1 to 1 configuration

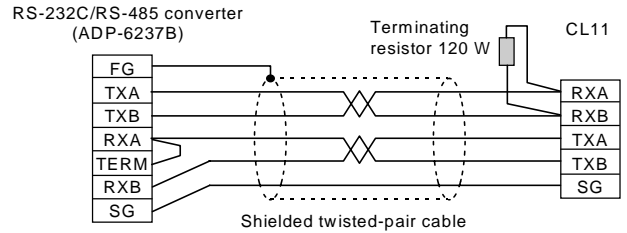

1 to N configuration

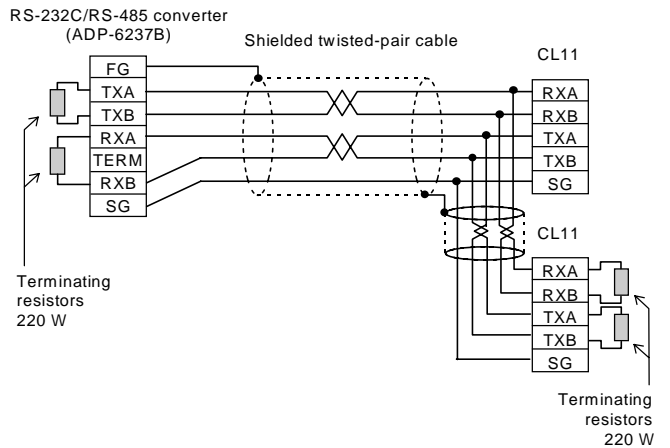

Note:

Refer to **EX100 Computer Link Function User's Manual?** for wiring precautions and the RS-232C/RS-485 converter (ADP-6237B).

7. When Using With EX100

Operation conditions:

- (1) EX100 CPU version 2.1 or later is required.
- (2) The maximum number of the CL11s on a EX100 is 2.
- (3) All the EX100's Computer Link commands can be used.
- (4) There is no limitation for register types and address ranges to be accessed.

Communication priority mode:

EX100's communication priority mode is also effective for CL11. In this mode, EX100 performs the CL11 service at the bottom of scan in batch. Therefore the communication response is quicker than the normal mode.

Refer to **EX100 User's Manual?** for details of the communication priority mode.

CL11 status flags:

EX100 does not support the CL11's status flags which reflect the CL11's operation status.

TOSHIBA

TOSHIBA CORPORATION

Industrial Equipment Department

1-1, Shibaura 1-chome, Minato-ku, Tokyo 105, Japan

Tel: (03)3457-4900

Cable: TOSHIBA TOKYO